

EXduro™

Cable & Instrumentation Management

Cable Ladder & Instrument Stand Product Guide

World leaders in the design and supply of Fibreglass Reinforced Plastic (FRP) Cable and Instrumentation Support Systems for industry.

The team at Treadwell is pleased to release the latest version of our FRP Cable and Instrumentation Management Systems Product Guide to the market.

Treadwell's product range has progressively expanded since our inception and now includes fibreglass cable ladder, struts, fasteners, instrumentation stands and more. We are also able to customise our solutions according to each client's need.

Our EXduro™ FRP Cable and Instrumentation Systems are designed for use in a multitude of environments where components are exposed to the elements, spills, electrical dangers, fumes, or chemicals. In such demanding conditions, FRP will outperform the standard traditional options on almost any site.

Now with warehouses and distribution centres throughout Australia and New Zealand, Treadwell is your one stop shop for FRP - we stock, we modify and we deliver to ensure that Treadwell is the name you can rely on.

A BRIEF HISTORY

At Treadwell Group, our core business divisions have been developed utilising the latest FRP technology. We are committed to providing true value to our customers through effective implementation of our comprehensive and diverse range of products and systems.

By continually innovating and having a consistent dedication to evolving our offerings, we are competent in delivering unparalleled solutions to a diversified index of industries which are by no means limited to the manufacturing, marine, oil and gas, infrastructure, and food and beverage sectors.

The progression of our products has been focused on ensuring extended design life in varied applications, enabling us to support our continuing commitment to satisfy and add value to our client's endeavours.



Treadwell Group Pty Ltd

Australia
P 1800 246 800
sales@treadwellgroup.com.au
treadwellgroup.com.au

New Zealand
P 0800 244 600
sales@treadwellgroup.co.nz
treadwellgroup.co.nz

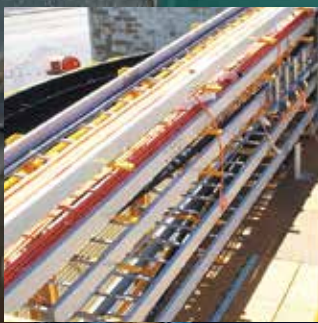



- 04 EXduro™ Cable Ladder Overview
 - 06 EXduro™ Technical Data
 - 08 EX-Series® Resin Systems
 - 09 EXduro™ Installation
-

EXduro™ Cable Ladder

- 11 EXduro™ Cable Ladder Fittings
 - 16 EXduro™ Cable Ladder Reducers
 - 18 EXduro™ Cable Ladder Splice Plates
 - 20 EXduro™ Cable Ladder Cover & Accessories
 - 24 EXduro™ Cable Ladder Specifications
-

EXduro™ Strut

- 25 EXduro™ Strut
 - 26 EXduro™ Strut Accessories
 - 28 EXduro™ Specifications
-

Instrumentation & Push Button Stands

- 29 Instrumentation & Push Button Stands
-
- 31 Chemical Resistance Guide



Quality Policy

Quality is at the forefront of Treadwell's working practices. With over 15 years of manufacturing to the highest quality standards, Treadwell prides itself on its implementation of strict quality control measures, and strives to supply products that surpass customers' expectations. The company works on a policy of continuous improvement.



Environmental Policy

Treadwell is conscious of the impact it has on the environment and its associated responsibilities. The company is committed to ensuring its operations satisfy both legal obligations and moral duties. Treadwell has been committed to sustainability for many years and is not just responding to current trends.

EXduro™ Cable Ladder

COVER HOLD DOWN CLAMP
EXD-CLA-CH(H)-316

FLAT COVER
EXD-CL-FC(W)-(RS)(C)

FLEXIBLE DIVIDER STRIP
EXD-CLA-FD(H)-(RS)(C)

STRAIGHT DIVIDER STRIP
EXD-CLA-SD(H)-(RS)(C)

ADJUSTABLE CLAMP
FOR DIVIDER STRIP
EXD-CLA-AC

CABLE LADDER CANTILEVER SUPPORT RACK
EXD-CLA-SR-SA(W)-(RS)(C)

HEAVY-DUTY COVER HOLD DOWN
EXD-CLA-HCH-C(H)(W)-(RS)(C)

DROPOUT
EXD-CLA-DO(W)-(RS)(C)

ADJUSTABLE VERTICAL SPLICE PLATE
EXD-CLP-VP-(H)AJ-(M)(C)

adder Overview

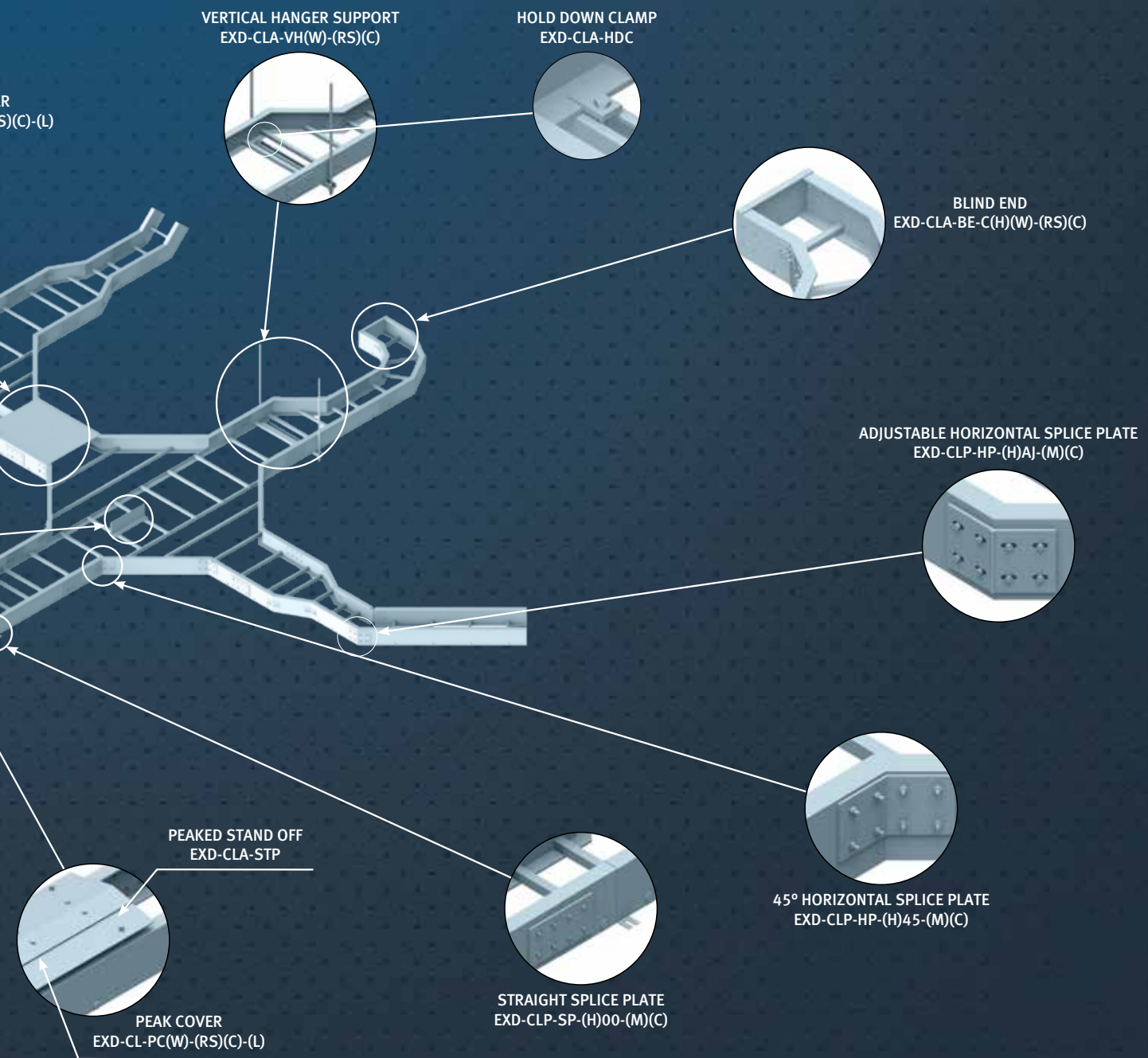

EXduro™ Technical Data

Typical Properties of EXduro™

Mechanical Properties	ASTM	Units	Value
Tensile Stress, LW	D-638	MPa	206.8
Tensile Stress, CW	D-638	MPa	48.2
Tensile Modulus, LW	D-638	GPa	20.7
Tensile Modulus, CW	D-638	GPa	5.5
Compressive Stress, LW	D-6641	MPa	206.8
Compressive Modulus, LW	D-6641	GPa	20.7
Compressive Modulus, CW	D-6641	GPa	6.9
In-Plane Shear Modulus	D-5379	GPa	2.76
Interlaminar Shear Strength	D-2344	MPa	24.1
In-Plane Shear Strength	D-5379	MPa	55.2
Pin-bearing Strength, LW	D-953 ^a	MPa	144.8
Pin-bearing Strength, CW	D-953 ^a	MPa	124.1

Thickness of Profile (mm)	ASTM Required	Strength (kN)
t=9.525mm	TBC	2.9
t=12.7mm	TBC	4.0
t=19.05mm	TBC	5.6

Pull-through Strength Per Fastener

*The pull-through strength per fastener corresponds to the thickness and the ASTM required.
 For example, when ASTM required is D-790 and t= 9.525mm, the pull-through strength is 2.9kN.

Physical Properties	ASTM	Units	Value
Barcol Hardness	D-2583	----	45
24 Hour Water Absorbtion	D-570	% max.	0.45
Density	D-792	g/cc	1.72-1.94
Coefficient of Thermal Expansion, LW	D-696	10 ⁻⁶ mm/mm/°C	12
Glass Transition Temperature	D-4065	°C	83

Electrical Properties	ASTM	Units	Value
Arc Resistance, LW	D-495	seconds	120
Dielectric Strength, LW	D-149	kv./mm	1.37
Dielectric Strength, PF	D-149	volts/mil.	200
Dielectric Constant, PF	D-150	@6ohz	5

Fire Retardant Polyester and Fire Retardant Vinyl Ester Structural Profiles:

Flammability Properties	ASTM	Units	Value
Tunnel Test	E-84	Flame Spread	25 max.
Flammability	D-635	----	Nonburning
NBS Smoke Chamber	E-662	Smoke Density 600-700	----

CW = Crosswise LW = Lengthwise PF = Perpendicular to Laminate Face

Note: 1 PSI = 6.894 K Pa; 1 Ft.-Lb./In. = 5.443 kg-m/m; * Specimen tested perpendicular to laminate face ** Indicates reported value measured in longitudinal direction; Depending on the specific glass content and resin, the strength and stiffness properties may be significantly higher.

Concentric Static Load (if required)

Various applications may require a given concentrated static load be imposed over and above the working load. These concentrated static load represents a static midspan weight applied between the side rail. When specified, the concentrated static load may be converted to an equivalent load (W) in kilograms per meter (kg/m) using the formula below and added to the static weight of cable in the ladder or tray. This combined load may be used to select a suitable load/span designation.

If the combined load exceeds the working load, please contact us. This data was obtained from the NEMA and NEC Standards Publications and other sources to assist in the proper selection of the most appropriate cable, ladder or tray from the EXduro™ range.

$$W_e = \frac{2 \times (\text{Concentrated Static Load})}{\text{span length (ft or m)}}$$

Thermal Contraction & Expansion

The thermal contraction and expansion based on various temperature differentials for fibreglass, steel and aluminum cable ladders are compared in the table on the right. The values represent the length of cable ladder that will produce a 15.9mm movement between expansion connectors for the indicated temperature difference. As shown, fibreglass shows the least movement and Treadwell has expansion connectors that suffices for 15.9mm total movement.

Fibreglass vs Steel vs Aluminum			
Temp. Differential	Fibreglass Ft. (m)	Steel Ft. (m)	Aluminum Ft. (m)
25°F (-4°C)	417 (126)	320 (97)	162 (49)
50°F (10°C)	208 (63)	160 (48)	81 (25)
75°F (24°C)	138 (42)	106 (32)	54 (16)
100°F (38°C)	104 (32)	80 (24)	40 (12)
125°F (52°C)	83 (25)	63 (19)	32 (10)
150°F (66°C)	69 (21)	53 (16)	26 (8)
175°F (79°C)	59 (17)	45 (13)	23 (6)

Effect of Temperature - FRP

When continuously exposed to elevated temperatures, strength properties of fibreglass are reduced. Working loads shall be reduced when based on the table to the right. Percentages shown are only an approximate figure. Please contact us for unusual temperature conditions. Below freezing temperatures do not adversely affect the load rating capability of the ladder. Fibreglass does not become brittle at below freezing temperatures. For temperatures above 93.3°C, a careful review of applications should be carried out.

Temp.	Polyester Strength %	Vinyl Ester Strength %
75°F (24°C)	100%	100%
100°F (38°C)	90%	100%
120°F (52°C)	78%	100%
150°F (66°C)	68%	90%
175°F (79°C)	60%	90%
200°F (93°C)	52%	75%

Note: The test values in the chart below were obtained from tests conducted by Treadwell's Vinyl Ester resin suppliers. The values shown, although obtained from an actual coupon test, are intended for illustrative purposes only, and not for use in design calculations. The values for polyester are slightly lower.

Test Temp. °F (°C)	-100° (-73°)	-50° (-46°)	0° (-18°)	50° (10°)	77° (25°)	100° (38°)	150° (66°)	200° (93°)	250° (121°)	300° (149°)
Flex. St., PSI, ASTM D790	101,500	84,100	79,500	72,300	68,100	66,300	58,700	27,400	13,200	9,200
Flex. Mod., PSI x 10 , ASTM D790	3.36	3.32	3.42	3.38	3.24	3.29	3.07	1.98	0.98	0.83
Tensile St., PSI, ASTM D638	84,100	70,400	63,900	58,000	56,100	54,600	49,900	41,800	29,600	22,000

EX-Series® Resin Systems

Options Overview

I-Series® is a premium Isophthalic Resin System. This system provides an intermediate level of chemical resistance and is the correct choice for areas subjected to splash and spill contact with harsh chemicals. This system is an excellent general-purpose resin and is a more favourably priced alternative to the Vinyl Ester system. This system has a flame spread of 15 or less.

V-Series® Vinyl Ester Resin System is a high quality and is the most chemical resistant system offered in the industry and has been developed for use in environments where fibreglass/FRP products are subject to frequent and direct contact with the harshest of chemicals: including a broad range of acids and caustics. This system has a flame spread of 15 or less.

P-Series® Phenolic Resin System is a system designed specifically for use where fire resistance, low smoke and low toxic fumes are critical. P-Series is typically used in offshore applications and confines spaces where such criteria are an absolute necessity. This system is tested in accordance with ASTM E-84. Various products also conforming to US Coast Guard Approvals, Level 2 and 3, are also offered by Treadwell. This particular Resin System has a flame spread rating of 5 and a smoke density rating of 5.

Standards Resin Systems Comparison Chart

	Chemical Resistance	Fire Retardance	Low Smoke	Halogen Free	Temperature Performance
I-Series® Isophthalic	● ● ● ● ●	● ● ● ● ●	—	—	● ● ● ●
V-Series® Vinyl Ester	● ● ● ● ●	● ● ● ● ●	—	—	● ● ● ● ●
P-Series® Phenolic	● ● ● ●	● ● ● ● ●	● ● ● ●	● ● ● ● ●	● ● ● ● ●

EXduro™ Features and Benefits vs. Traditional Alternatives

	EXduro™	Stainless Steel	Galvanised Steel	Aluminium	Polyurethane
Chemical Resistance	● ● ● ● ●	● ● ● ●	●	● ● ●	● ● ● ●
Strength	● ● ● ● ●	● ● ● ● ●	● ● ● ● ●	● ● ● ● ●	● ● ●
Lightweight	● ● ● ● ●	●	●	● ● ● ● ●	
Electrical Resistance	● ● ● ● ●	●	●	●	● ● ● ● ●
Cost Effectiveness	● ● ● ● ●	● ● ●	● ● ● ●	● ●	● ● ● ● ●

Overview

EXduro™ cable ladder should be installed in compliance with the standards set by NEMA Publication FG-1. EXduro™ cable ladders can be manufactured according to specifications with pre-fabricated cable ladder and fittings.

Do observe common safety practices when assembling ladder and fittings in the field. Where possible, assemble in well-ventilated areas as dust from field cuts can accumulate. This presents no serious health hazard but can cause irritation and, if allowed to accumulate with grease and other machining lubricants, can become abrasive. Personnel should wear safety goggles, dust mask, coveralls or a shop coat when sawing, machining and sanding.

Heat softens the bonding resin in fibreglass and it is recommended to avoid generation of excessive heat especially in machine operation.

Avoid excessive pressure when sawing, drilling, routing, etc. Use carbide-tipped drill bits and saw blades to extend tool life. The use of lubricant during machining in the field is not recommended.

EXduro™ cable ladder and fittings should be secured properly during field cut operations to avoid chipping of the material at cut edges. We recommend the use of Treadwell EX-Series® sealant for sealing surfaces and cut edges after field cuts are made.

When using adhesives, be sure to prepare the surface properly before application. A combination of mechanical fasteners and adhesives is recommended for the strongest connections.



EXduro™ Cable Ladder

EXduro™ Cable Ladders

What are EXduro™ FRP Cable Ladders?

For environments where corrosive elements play a crucial part in material selection, Treadwell has developed its FRP cable ladders as a strong alternative to metal cable ladders. Being lightweight, it allows for easier installation or onsite fabrication as well as giving the cable ladder a high strength to weight ratio.

EXduro™ fibreglass cable ladders has several other useful benefits. It is both a UV resistant and fire retardant system. Transparent to RF frequencies and electrically non-conductive are other positives it can bring to any design.

EXduro™ fibreglass cable ladders are also a cost competitive, performance proven alternative to metal systems for that corrosive/chemical environment to run your electrical cable and instrumentation pipe work. With little or no ongoing maintenance, Treadwell's system is supplied with both FRP and stainless steel fasteners to suit your application.

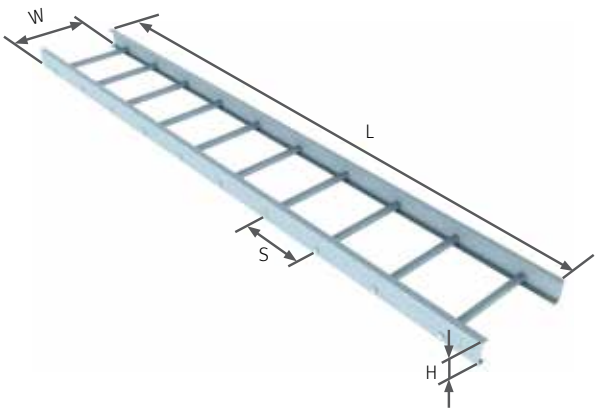
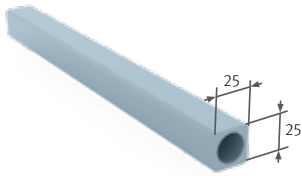
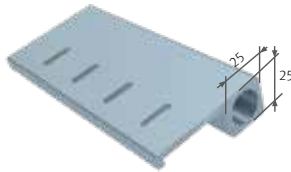
EXduro™ Typical C Rail Straight Section	
C Rail Straight Section	Standard Rung
	
	Marine Rung
	

EXD-CL-C(H)(W)-(RT)(S)-(RS)(C)-(L)						
Side Rail Height (H)	Width (W)	Rung Type (RT)	Rung Spacing (S)	Resin (RS)	Colour (C)	Length (L)
50mm (050) N	150mm (150) C	Standard Rung (S) C	150mm (150)	I-Series® Isophthalic(I) C	Light Grey (LG) C	3m (1) N
75mm (075) N	300mm (300) C	Marine Rung (M) N	250mm (250)	V-Series® Vinyl Ester(V) C	Dark Grey (DG) C	6m (2) C
*100mm (100) C	450mm (450) C	Combined Rung (C) N	300mm (300)	P-Series® Phenolic(P) N	Custom Colour (CC) N	
**150mm (150) C	600mm (600) C		450mm (450)			
200mm (200) N	750mm(750) C					
	900mm (900) C					

* NEMA 8A : 1.5 Safety Factor

** NEMA 8B - 20C : 1.5 Safety Factor

Note: 450mm rung spacing not available for 750mm and 900mm widths

N Non-standard item **C** Commonly stocked

Cable Ladder Fittings

Treadwell's range of pre-fabricated for EXduro™ fibreglass cable ladder fittings are readily available when you need to change the ladders' direction or work around a site.

All sizes of cable ladder are offered with a full range of fittings that allow you to bend, tee, cross, rise, or reduce the laying widths as required. This gives the user flexibility and ease to design and create a cable ladder system to support cables onsite anytime.

EXD-CLF-(FT)(ϕ)-C(H)(W)(RT)(R)-(RS)(C)							
Fitting Type (FT)	Angle (ϕ)	Side Rail Height (H)	Width (W)	Rung Type (RT)	Radius (R)	Resin (RS)	Colour (C)
Horizontal Bend (HB)	30° (30)	50mm (050)	150mm (150)	Standard Rung (S)	300mm (300)	I-Series® Isophthalic(I)	Light Grey (LG)
Horizontal Tee (HT)	45° (45)	75mm (075)	300mm (300)	Marine Rung (M)	450mm (450)	V-Series® Vinyl Ester(V)	Dark Grey (DG)
Horizontal Cross (HX)	60° (60)	100mm (100)	450mm (450)		600mm (600)	P-Series® Phenolic(P)	Custom Colour (CC)
Vertical Intward Bend (VI)	90° (90)	150mm (150)	600mm (600)		900mm (900)		
Vertical Outward Bend (VO)		200mm (200)	750mm (750)	Direct Bend (000)			
			900mm (900)				

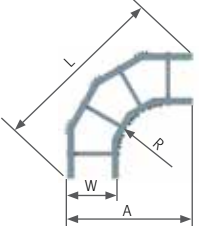
90° Horizontal Bend		Dimension (mm)							
Code		R-300		R-450		R-600		R-900	
EXD-CLF-HB90-C(H)(W)(RT)(R)-(RS)(C)	Width	A	L	A	L	A	L	A	L
	150	606	858	756	1070	906	1282	1206	1706
	300	756	1070	906	1282	1056	1494	1356	1918
	450	906	1282	1056	1494	1206	1706	1506	2130
	600	1056	1494	1206	1706	1356	1918	1656	2342
	750	1206	1706	1356	1918	1506	2130	1806	2555
	900	1356	1918	1506	2130	1656	2342	1956	2767

EXduro™ Cable Ladder Fittings

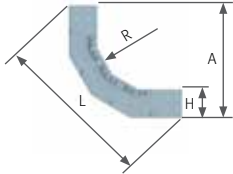
90° Vertical Inward Bend		Dimension (mm)							
Code		R-300		R-450		R-600		R-900	
EXD-CLF-VI90-C(H)(W)(RT)(R)-(RS)(C)	H	A	L	A	L	A	L	A	L
	50	501	708	651	920	801	1132	1101	1557
	75	526	744	676	956	826	1168	1126	1593
	100	552	780	702	992	852	1204	1152	1629
	150	602	851	752	1063	902	1276	1202	1700
	200	653	924	803	1136	953	1348	1253	1772

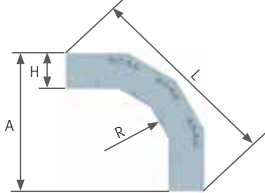
90° Vertical Outward Bend		Dimension (mm)							
Code		R-300		R-450		R-600		R-900	
EXD-CLF-VO90-C(H)(W)(RT)(R)-(RS)(C)	H	A	L	A	L	A	L	A	L
	50	501	708	651	920	801	1132	1101	1557
	75	526	744	676	956	826	1168	1126	1593
	100	552	780	702	992	852	1204	1152	1629
	150	602	851	752	1063	902	1276	1202	1700
	200	653	924	803	1136	953	1348	1253	1772

EXduro™ Cable Ladder Fittings

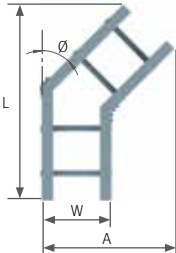
30°/ 45°/ 60° Horizontal Bend for 600mm radius		Dimension (mm)					
Code		30° Angle (∅)		45° Angle (∅)		60° Angle (∅)	
EXD-CLF-HB(∅)-C(H)(W)(RT)(R)-(RS)(C)	W	A	L	A	L	A	L
	150	317	658	443	791	589	880
	300	467	733	593	897	739	1010
	450	617	808	743	1003	889	1140
	600	767	883	893	1109	1039	1270
	750	917	958	1043	1215	1189	1400
	900	1067	1033	1193	1321	1339	1530

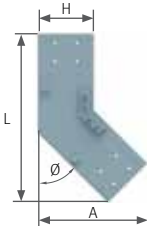
30°/45°/60° Vertical Inward Bend for 600mm radius		Dimension (mm)					
Code		30° Angle (∅)		45° Angle (∅)		60° Angle (∅)	
EXD-CLF-VI(∅)-C(H)(W)(RT)(R)-(RS)(C)	H	A	L	A	L	A	L
	50	206	605	333	716	481	789
	75	232	618	358	734	506	811
	100	257	631	383	752	532	833
	150	307	656	434	788	582	876
	200	359	682	485	824	633	921

EXduro™ Cable Ladder Fittings

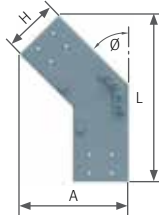
30°/45°/60° Vertical Outward Bend for 600mm radius		Dimension (mm)					
Code		30° Angle (∅)		45° Angle (∅)		60° Angle (∅)	
EXD-CLF-VO(∅)-C(H)(W)(RT)(R)-(RS)(C)	H	A	L	A	L	A	L
	50	206	605	333	716	481	789
	75	232	618	358	734	506	811
	100	257	631	383	752	532	833
	150	307	656	434	788	582	876
	200	359	682	485	824	633	921

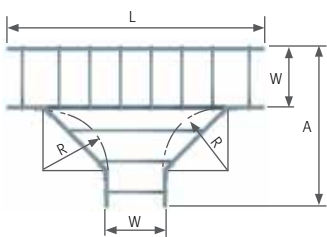
Horizontal Tee		Dimension (mm)							
Code		R-300		R-450		R-600		R-900	
EXD-CLF-HT90-C(H)(W)(RT)(R)-(RS)(C)	W	A	L	A	L	A	L	A	L
	150	822	1482	972	1782	1122	2082	1422	2682
	300	972	1632	1122	1932	1272	2232	1572	2832
	450	1122	1782	1272	2082	1422	2382	1722	2982
	600	1272	1932	1422	2232	1572	2532	1872	3132
	750	1422	2082	1572	2382	1722	2682	2022	3282
	900	1572	2232	1722	2532	1872	2832	2172	3432

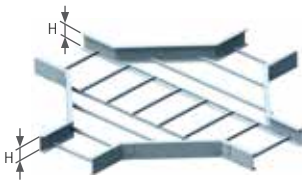
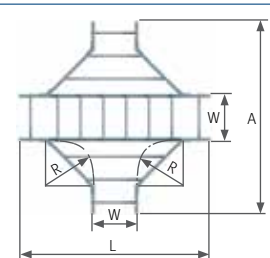
Horizontal Cross		Dimension (mm)							
Code		R-300		R-450		R-600		R-900	
EXD-CLF-HX90-C(H)(W)(RT)(R)-(RS)(C)	W	A	L	A	L	A	L	A	L
	150	1482	1482	1782	1782	2082	2082	2682	2682
	300	1632	1632	1932	1932	2232	2232	2832	2832
	450	1782	1782	2082	2082	2382	2382	2982	2982
	600	1932	1932	2232	2232	2532	2532	3132	3132
	750	2082	2082	2382	2382	2682	2682	3282	3282
	900	2232	2232	2532	2532	2832	2832	3432	3432

Benefits of FRP



No Hot Work or Welding Required

FRP is very simply modified or fabricated on site with easy to use hand tools. These can be done without the hassle of first needing to obtain hot work permits.



Light Weight, High Strength & Easy Installation

Treadwell's FRP products and systems are lightweight and very manageable. FRP has specific gravity one quarter that of steel and two thirds of aluminium.



Environmentally Sound

Related to the lightweight, low need for maintenance and long design life of FRP, the reduced lifecycle cost and environmental footprint are highly sought after characteristics in the modern world. Continual resin formulation fine tuning and development can further raise this environmental profile of composites.

EXduro™ Cable Ladder Reducers

Cable Ladder Reducers

EXduro™ cable ladder reducers are available in widths of 150mm to 900mm with alternative widths available to meet market requirements. Reducers can be manufactured accordingly in standard width increments or decrements i.e. from 600mm to a 150mm width or vice versa.

EXD-CLR-(RT)C(H)(W1)(W2)(RT)-(RS)(C)						
Reducer Type (RT)	Side Rail Height (H)	Larger Width (W1)	Smaller Width (W2)	Rung Type (RT)	Resin (RS)	Colour (C)
Right Reducer (R)	50mm (050)	300mm (300)	150mm (150)	Standard Rung (S)	I-Series® Isophthalic(I)	Light Grey (LG)
Left Reducer (L)	75mm (075)	450mm (450)	300mm (300)	Marine Rung (M)	V-Series® Vinyl Ester(V)	Dark Grey (DG)
Straight Reducer (S)	100mm (100)	600mm (600)	450mm (450)		P-Series® Phenolic(P)	Custom Colour (CC)
	150mm (150)	750mm (750)	600mm (600)			
	200mm (200)	900mm (900)	750mm (750)			

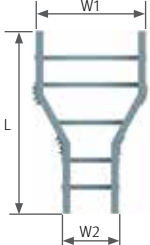
Straight Reducer		W1 (mm)					
Code		900	750	600	450	300	
EXD-CLR-SC(H)(W1)(W2)(RT)-(RS)(C)							
	150	1095	1020	945	870	795	
	300	1020	945	870	795	---	
	450	945	870	795	---	---	
	600	870	795	---	---	---	
	750	795	---	---	---	---	
	Dimension "L" (mm)						

EXduro™ Cable Ladder Reducers

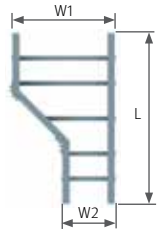
Left Hand Reducer		W1 (mm)				
Code		900	750	600	450	300
 	150	1470	1320	1170	1020	870
	300	1320	1170	1020	870	---
	450	1170	1020	870	---	---
	600	1020	870	---	---	---
	750	870	---	---	---	---
	Dimension "L" (mm)					

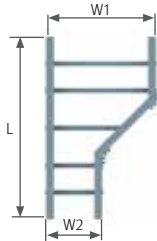
Right Hand Reducer		W1 (mm)				
Code		900	750	600	450	300
 	150	1470	1320	1170	1020	870
	300	1320	1170	1020	870	---
	450	1170	1020	870	---	---
	600	1020	870	---	---	---
	750	870	---	---	---	---
	Dimension "L" (mm)					

EXduro™ Cable Ladder Reducers



EXduro™ Cable Ladder Splice Plates

EXduro™ splice plates are available in both horizontal and vertical orientations. We also offer the accompanying accessories separately. These plates are non-conductive and do not react to electric and magnetic fields.

EXD-CLP-(PT)-(H)(∅)-(M)(C)				
Plate Type (PT)	Side Rail Height (H)	Angle (∅)	Material (M)	Colour (C)
Straight Plate (SP)	50mm (050)	22.5° (22)	I-Series® Isophthalic(I)	Light Grey (LG)
Vertical Plate (VP)	75mm (075)	30° (30)	V-Series® Vinyl Ester(V)	Dark Grey (DG)
Horizontal Plate (HP)	100mm (100)	45° (45)	P-Series® Phenolic(P)	Custom Colour (CC)
Heavy Duty Splice Plate (DP)	150mm (150)	90° (90)	316 Stainless Steel (316)	
	200mm (200)	Straight (00)		
		Adjustable Angle (A)		

Notes:

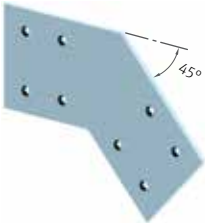
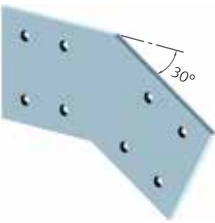
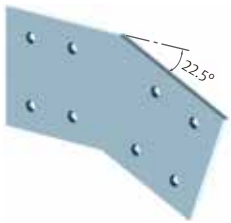

1. 316 Stainless Steel M10 Bolt Sets included.
2. Steel Splice plates have no colour options

Splice Plate Straight Section	Splice Plate 90° Vertical	Splice Plate Heavy Duty
EXD-CLP-SP-(H)00-(M)(C)	EXD-CLP-VP-(H)90-(M)(C)	EXD-CLP-HD-(H)00-(M)(C)
	 Field Drilling Required	

Splice Plate 45° Vertical	Splice Plate 30° Vertical	Splice Plate 22.5° Vertical
EXD-CLP-VP-(H)45-(M)(C)	EXD-CLP-VP-(H)30-(M)(C)	EXD-CLP-VP-(H)22-(M)(C)
		

EXduro™ Cable Ladder Splice Plates

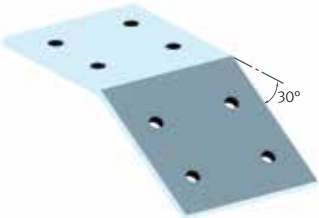
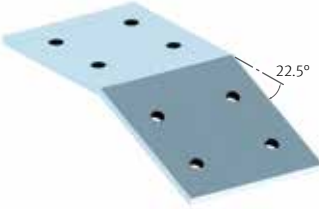
Splice Plate Adjustable Vertical	Splice Plate 90° Horizontal	Splice Plate 45° Horizontal
EXD-CLP-VP-(H)A-(M)(C)	EXD-CLP-HP-(H)90-(M)(C)	EXD-CLP-HP-(H)45-(M)(C)
		

Splice Plate 30° Horizontal	Splice Plate 22.5° Horizontal	Splice Plate Adjustable Horizontal
EXD-CLP-HP-(H)30-(M)(C)	EXD-CLP-HP-(H)22-(M)(C)	EXD-CLP-HP-(H)A-(M)(C)
		

Benefits of FRP



Long Term Cost Benefits

Long service life, minimal maintenance costs and low installation costs all combine to provide a very competitive solution over time.



Non-Conductive & RF Transmission Transparent

FRP is transparent to radio frequency transmission and is non-conductive in nature. This makes the material ideal for applications that need to avoid electrical currents and radio frequency.



Virtually Maintenance Free

Given the nature of FRP, any system utilising it is virtually maintenance free, thus keeping maintenance costs as low as possible.

EXduro™ Cable Ladder Cover & Accessories

Cable Ladder Accessories

Treadwell's EXduro™ range is doubtless one of the most extensive ranges of FRP cable ladder accessories available on the market today. With unmatched quality and service, we offer a variety of styles, materials and finishes available to support virtually any commercial and industrial cable support application requirement in any environment.

Cable Ladder Cover

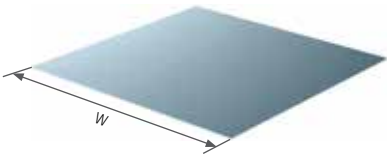
Flat Cover	
EXD-CL-FC(W)-(RS)(C)-(L)	Width (W)
	150mm (150)
	300mm (300)
	450mm (450)
	600mm (600)
	750mm (750)
	900mm (900)

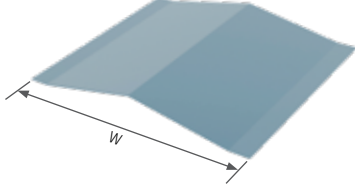
Peaked Cover *	
EXD-CL-PC(W)-(RS)(C)-(L)	Width (W)
	300mm (300)
	450mm (450)
	600mm (600)
	750mm (750)
	900mm (900)

Cable Ladder Fitting Cover

EXD-CLF-(CT)(Φ)-(CT)(W)(R)-(RS)(C)				
Cover Type (CT)	Fitting Type (FT)	Angle (θ)	Width (W)	Radius (R)
Flat Cover (FC)	Horizontal Bend (HB)	30° (30)	150mm (150)	300mm (300)
Peaked Cover (PC)	Horizontal Tee (HT)	45° (45)	300mm (300)	450mm (450)
	Horizontal Cross (HX)	60° (60)	450mm (450)	600mm (600)
	Vertical Intward Bend (VI)	90° (90)	600mm (600)	900mm (900)
	Vertical Outward Bend (VO)		750mm (750)	Direct Bend (000)
			900mm (900)	

Cable Ladder Reducer Cover

EXD-CLR-(RT)(CT)(W1)(W2)-(RS)(C)			
Cover Type (CT)	Reducer Type (RT)	Larger Width (W1)	Smaller Width (W2)
Flat Cover (FC)	Right Reducer (R)	300mm (300)	150mm (150)
Peaked Cover (PC)	Left Reducer (L)	450mm (450)	300mm (300)
		600mm (600)	450mm (450)
	Straight Reducer (S)	750mm (750)	600mm (600)
		900mm (900)	750mm (750)

Cover Connection

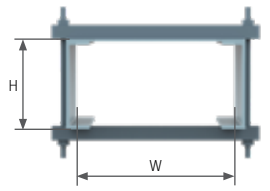

Flat Stand Off
EXD-CLA-STO

* Peaked covers for 100mm high cable ladders and fittings should be trimmed on site where splice plates are located.

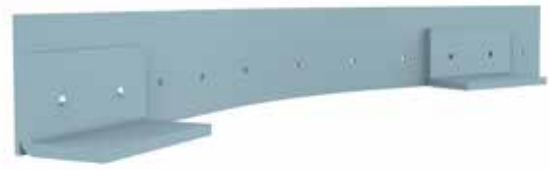

Heavy Duty Cover Hold Down		
EXD-CLA-HCH-C(H)(W)-(RS)(C)	Side Rail Height (H)	Width (W)
	50mm (050)	150mm (150)
	75mm (075)	300mm (300)
	100mm (100)	450mm (450)
	150mm (150)	600mm (600)
	200mm (200)	750mm (750)
		900mm (900)

Floor / Panel Flange Plate	
EXD-CLA-FP(H)-(RS)(C)	Rail Height (H)
 <p>Field Drilling Required</p>	75mm (075)
	100mm (100)
	150mm (150)
	200mm (200)

Straight Divider Strip	Flexible Divider Strip
EXD-CLA-SD-(RS)(C)	EXD-CLA-FD-(RS)(C)
	 <p>Holes are pre-drilled, Equal Leg Angle fixings can be adjusted according to the actual rung position</p>

Adjustable Clamp for Divider Strip	Hold Down Clamp
EXD-CLA-AC	EXD-CLA-HDC
	

EXduro™ Cable Ladder Cover & Accessories

Non-Metallic Rivet	Drop Out	
EXD-CLA-DV	EXD-CLA-DO(W)-(RS)(C)	
 <p>For securing cover material and divider strip.</p>		
		Width (W)
	150mm (150)	600mm (600)
	300mm (300)	750mm (750)
	450mm (450)	900mm (900)

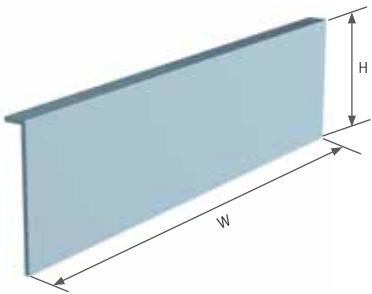
Blind End	Side Rail Height (H)	Width (W)
EXD-CLA-BE-C(H)(W)-(RS)(C)	50mm (050)	150mm (150)
	75mm (075)	300mm (300)
	100mm (100)	450mm (450)
	150mm (150)	600mm (600)
	200mm (200)	750mm (750)
		900mm (900)

Benefits of FRP



No Protective Coating Required

Treadwell's unique surface finishing system ensures UV stability in exposed applications, directly eliminating the need for costly surface treatment.



Corrosion, Rust & Rot Proof

Treadwell's superior resin systems offer exceptional resistance to acids, salts and alkalis. At the same time, our FRP systems are rot and termite proof.

EXduro™ Cable Ladder Accessories

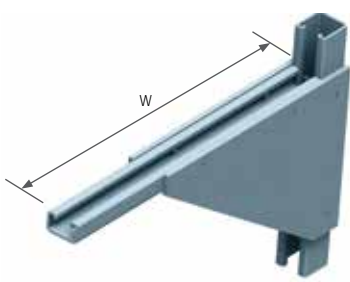
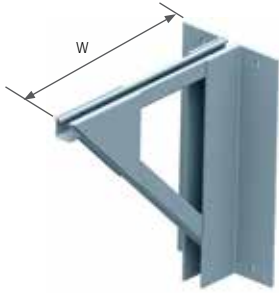
Cable Ladder Cantilever Support Racks			
EXD-CLA-SR-SA(W)-(RS)(C)		EXD-CLA-SR-SB(W)-(RS)(C)	
Type A 	Width (W)	Type B 	Width (W)
	150mm (150)		600mm (600)
	300mm (300)		750mm (750)
	450mm (450)		900mm (900)
	600mm (600)		

Vertical Hanger Support		Resin Sealer Kit	
EXD-CLA-VH(W)-(RS)(C)		CPX-EX-SK-500	
		500g	
Width (W)		 <p>Seals exposed fibres after any field cuts. Restores gloss and luster to weathered fibreglass. Seals exposed FRP threads after installation of fibreglass threaded rod and hex nuts. For polyester and Vinyl Ester resin products. Clear color.</p>	
150mm (150)	600mm (600)		
300mm (300)	750mm (750)		
450mm (450)	900mm (900)		

Benefits of FRP



Design Flexibility

The unique capabilities of conforming partial functionality to the use or application, ease to manufacture and to personalise shapes and aesthetics are just some of the key benefits that draw designers, engineers and architects to composite materials.



Competitive Vs Traditional Materials

FRP is manufactured from a more economically sound raw material base than metallic alternatives, and is far more structurally sound when compared to timber and plastic materials.

Specification - Cable Ladder

General

1.0 Scope

1.1 The cable ladder system shall conform to the material and fabrication requirements as per this specification.

2.0 Standards

- 2.1 The cable ladder system shall conform to applicable sections of:
 - 2.1.1 NEMA Standard FG-1 (latest edition)
 - 2.1.2 National Electric Code (NEC)
 - 2.1.3 ASTM E-84

3.0 Working Load Capacity

3.1 There shall be three working load classifications and four span categories

Class	Working Load	FOS
A	74.4kg/m	1.5
B	111.6kg/m	1.5
C	148.8kg/m	1.5

Class	Span
8	2.44m
12	3.66m
16	4.87m
20	6.09m

3.2 The load/span class designation of below table shall apply.

LOAD/SPAN CLASS DESIGNATIONS		
Working Load (kg/m)	Support Span (m)	Class Designation
74.4	2.44	8A
111.6	2.44	8B
148.8	2.44	8C
74.4	3.66	12A
111.6	3.66	12B
148.8	3.66	12C
74.4	4.87	16A
111.6	4.87	16B
148.8	4.87	16C
74.4	6.09	20A
111.6	6.09	20B
148.8	6.09	20C

3.3 EXdure™ cable ladder's NEMA Class table.

Side Rail Height (mm)	Loading Depth (mm)	NEMA Class FG-1	Safety Factor
100	71	12A	1.5
100	71	16A	1.2
152.4	121	20B	2
152.4	121	20C	1.5

4.0 Material

- 4.1 The glass fiber to resin content shall be maintained between 45 to 55 percent by weight in all pultruded components except flat sheet which shall be 35 to 45 percent; and 25 to 45 percent by weight in all molded components.
- 4.2 All composite material shall have an ultraviolet light inhibiting chemical additive to resist UV degradation.
- 4.3 All composite material shall be fire retardant and have a flame spread rating of 25 or less (Class 1 Rating) when tested in accordance with ASTM E-84.
- 4.4 All pultruded products shall have a complete surfacing veil to provide maximum chemical and UV protection.

5.0 Construction

- 5.1 Straight section ladder shall be fiberglass reinforced meeting all the requirements herein described.
 - 5.1.1 The side rail members must turn in.
 - 5.1.2 All rung to side member connections shall have both a mechanical and a chemical (adhesive) lock. The ladder shall be assembled by the use of a locking pin made of fiberglass reinforced thermoplastic. The locking pin shall be inserted under pressure with a high strength, chemical resistant adhesive.
 - 5.1.3 All bonded connections must be sanded to maximize adhesion and structural integrity.
 - 5.1.4 The ladder interior shall be clear of all projections or sharp objects.
 - 5.1.5 All straight section lengths shall be pre-drilled to accept connector plates.
 - 5.1.6 All cut ends and drilled holes (factory and field) shall be resin coated.
- 5.2 Fittings are to be pre-fabricated and shall meet all the requirements herein described.
 - 5.2.1 All fittings shall be pre-drilled to accept connector plates.
 - 5.2.2 All fittings shall be designed and installed so as to have the same load carrying capacity as the straight sections.
 - 5.2.3 Rung to side member connections shall have both a mechanical and/or chemical (adhesive) lock. Fittings shall be assembled by use of a locking pin made of fibreglass reinforced thermoplastic and/or a stainless steel rivet. The locking pin shall be inserted under pressure with a high strength chemical resistant adhesive.
- 5.3 Connector Plates and Fasteners:
 - 5.3.1 Connector plates shall be fibreglass and designed with sufficient strength so they may be installed between 0.2 and 0.3 of the length of the span from the support without derating the load carrying capacity of the ladder.
 - 5.3.2 Connector plates for conductive ladder shall be stainless steel.
 - 5.3.3 Fasteners shall be 316 stainless steel M10 bolt sets for cable ladder splice plates.

Support Location Guidelines*

Correct

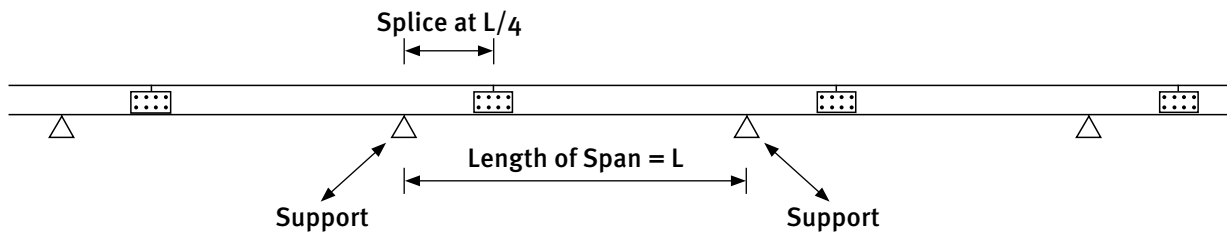

Incorrect

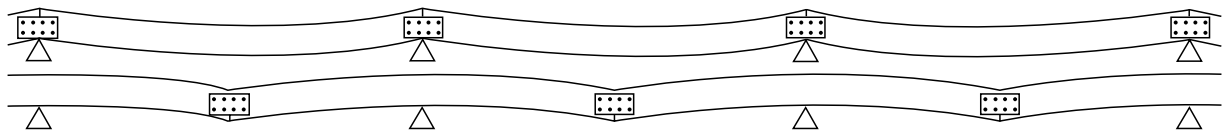

Refer to section 5.3

5.4 Accessories

5.4.1 The manufacturer shall be capable of providing all necessary parts (i.e. clamps, support assemblies, etc.) for the installation of a complete fibreglass ladder system.

5.5 Warning

5.5.1 Treadwell's cable ladder system is designed as a support for power or control cables, or both; it is not intended or designed to be a walkway for personnel. The user is urged to display appropriate warning cautioning against the use of this support as a walkway.

5.5.2 Rungs shall only be horizontally installed.

6.0 Acceptable Manufacturer

6.1 The fibreglass cable management system component shall be manufactured by Treadwell Group Pty Ltd of Australia.

N Non-standard item **C** Commonly stocked



WARNING

NOT TO BE USED AS A WALKWAY

Warning! Not to be used as a walkway, ladder or support for personnel. To be used only as a mechanical support for cables and tubing.

EXduro™ Strut

EXduro™ Strut		
Channel Framing (Solid & Punched)		
EXD-DS-P22-(RS)(C)-(L) (Punched)	EXD-DS-P41-(RS)(C)-(L) (Punched)	EXD-DS-P45-(RS)(C)-(L) (Punched)*
EXD-DS-S22-(RS)(C)-(L) (Solid)	EXD-DS-S41-(RS)(C)-(L) (Solid)	EXD-DS-S45-(RS)(C)-(L) (Solid)*
EXD-DS-S74-(RS)(C)-(L) (Solid)*	EXD-DS-S82-(RS)(C)-(L) (Solid)*	* Please be advised that the marked products are not commonly stocked. Please contact us for the confirmation of lead times.
Resin (RS)	Colour (C)	Length (L)
I-Series® Isophthalic(I)	Light Grey (LG)	3m (1)
V-Series® Vinyl Ester(V)	Dark Grey (DG)	6m (2)
P-Series® Phenolic(P)	Custom Colour (CC)	

EXduro™ Strut Accessories

Connector Plates

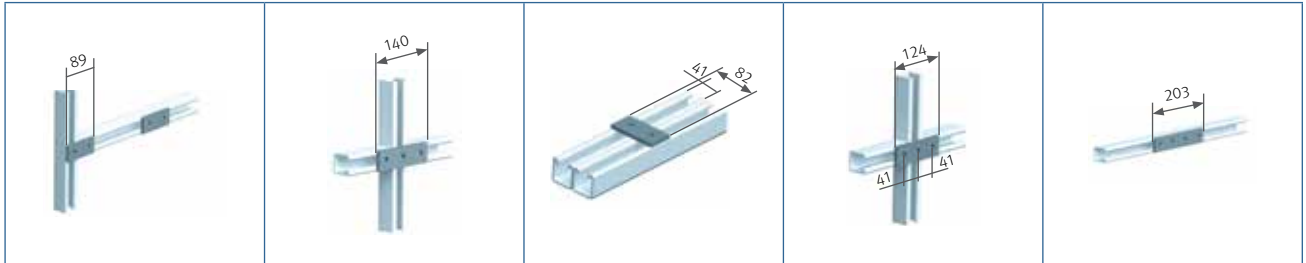

EXD-DSA-CP01-(RS)(C) EXD-DSA-CP02-(RS)(C) EXD-DSA-CP03-(RS)(C) EXD-DSA-CP04-(RS)(C) EXD-DSA-CP05-(RS)(C)

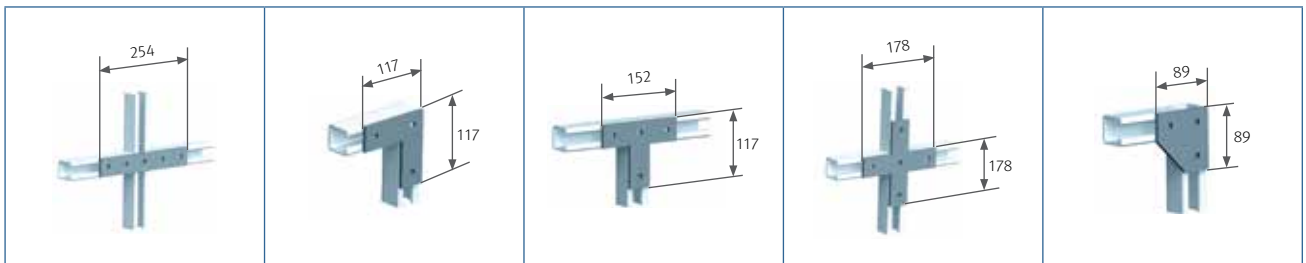

EXD-DSA-CP06-(RS)(C) EXD-DSA-CP07-(RS)(C) EXD-DSA-CP08-(RS)(C) EXD-DSA-CP09-(RS)(C) EXD-DSA-CP10-(RS)(C)

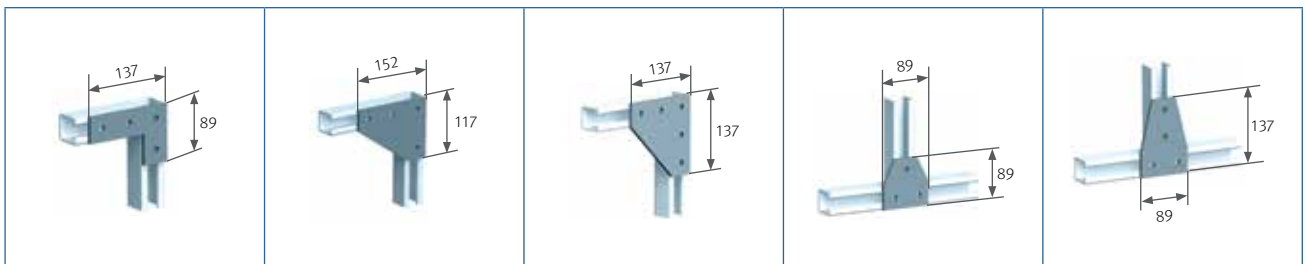

EXD-DSA-CP11-(RS)(C) EXD-DSA-CP12-(RS)(C) EXD-DSA-CP13-(RS)(C) EXD-DSA-CP14-(RS)(C) EXD-DSA-CP15-(RS)(C)

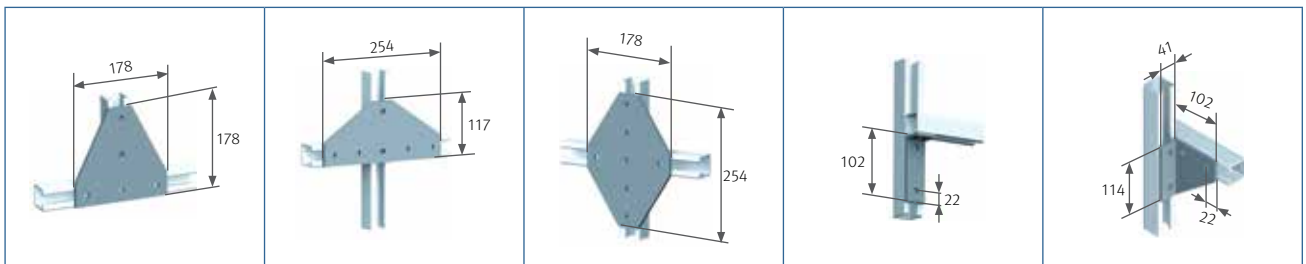

EXD-DSA-CP16-(RS)(C) EXD-DSA-CP17-(RS)(C) EXD-DSA-CP18-(RS)(C) EXD-DSA-CP19-(RS)(C) EXD-DSA-CP20-(RS)(C)

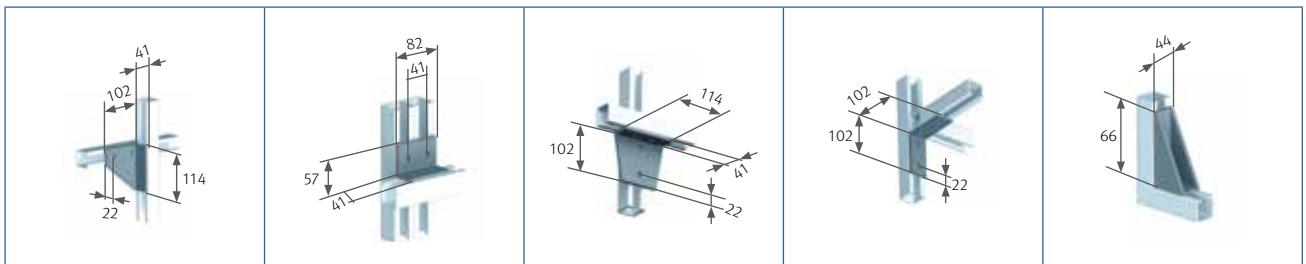

EXD-DSA-CP21-(RS)(C) EXD-DSA-CP22-(RS)(C) EXD-DSA-CP23-(RS)(C) EXD-DSA-CP24-(RS)(C) EXD-DSA-CP25-(RS)(C)

EXduro™ Strut

EXduro™ Strut Single Post Base

EXD-DSA-BS41

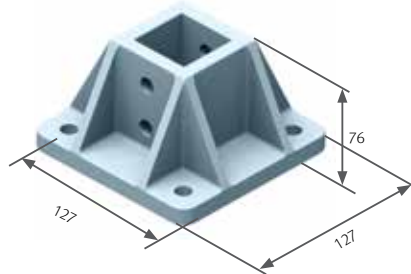

EXduro™ Strut FRP/GRP Channel Nut

EXD-DSA-CN(D)

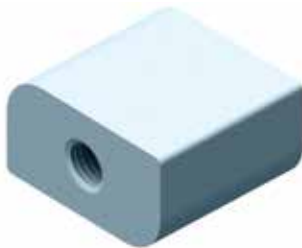

Rod size (D)

6mm (06)

8mm (08)

10mm (10)

12mm (12)

Non-Metallic Universal Pipe Clamp

EXD-DSA-PC(D)

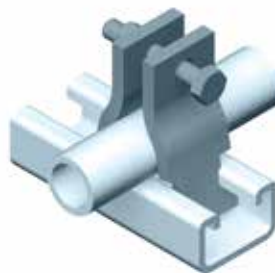

Pipe size (D)

12.7mm (012)

19.0mm (019)

25.4mm (025)

31.7mm (032)

38.1mm (038)

50.8mm (051)

63.5mm (064)

76.2mm (076)

88.9mm (089)

101.6mm (102)

EXduro™ Strut Window Clamp

EXD-DSA-WC

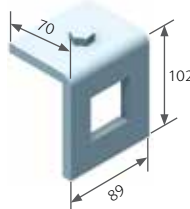

EXduro™ Strut Cable Cleat

EXD-DSA-SCC(D)



EXduro™ Strut Cable Clamp

EXD-DSA-TCC(D)



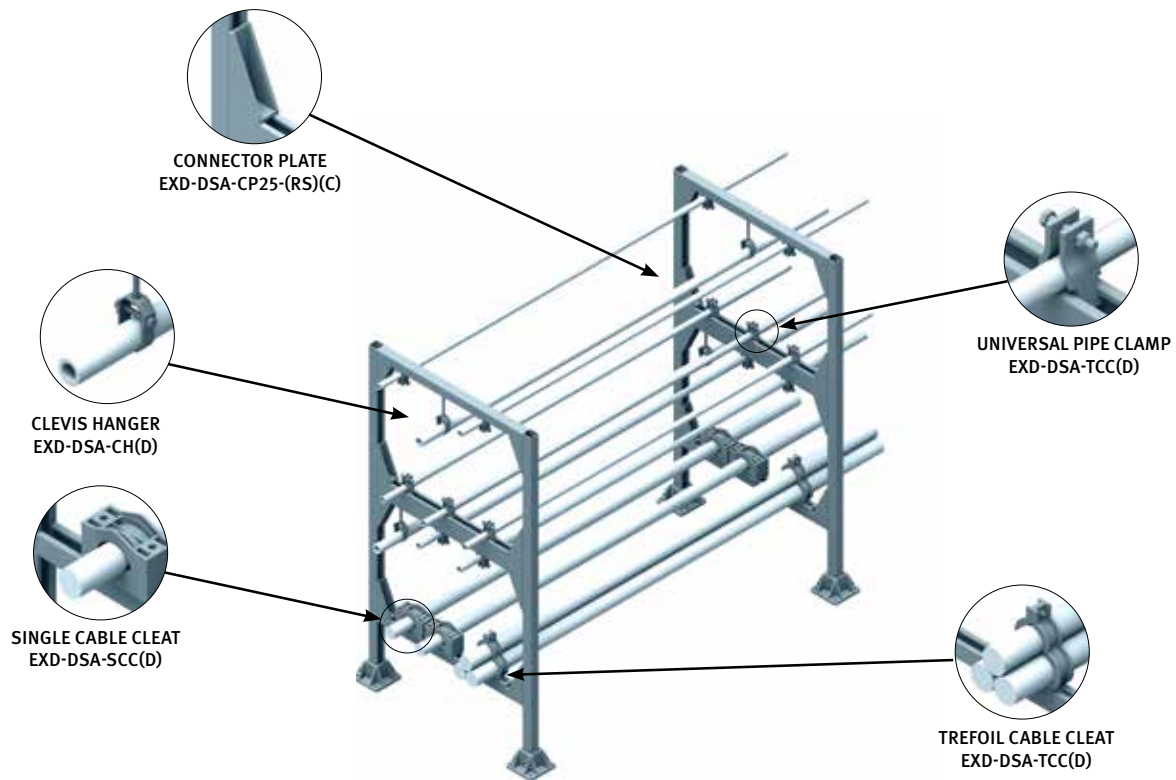

Specification - EXduro™ Strut

1.0 Scope

- 1.1 This specification covers the requirements for EXduro™ Strut non-metallic Channel Framing Systems & Accessories

2.0 Standards

- 2.1 All channel shall have a flame spread rating of 15 or less, and the Smoke Developed Index shall have a density of 550 or less when tested in accordance with the provisions of ASTM E-84.
- 2.2 All channel shall have a surfacing veil over the entire surface in addition to a UV inhibitor in the resin system to protect against degradation from ultra-violet light.

3.0 Materials

- 3.1 All channel shall be manufactured by the pultrusion process, and contain a minimum of 50% glass by weight.

4.0 Non-Metallic Pipe Clamps

- 4.1 All pipe clamps shall be manufactured by the injection molding process with an impact modified, 30% glass filled thermoplastic polyester resin.

- 4.2 All pipe clamps interlock with the channel framing described above.

- 4.3 All pipe clamps shall be designed for rigid PVC coated steel, Schedule 40 and 80 PVC, and filament wound fiberglass pipe or conduit. Clamps shall be adjustable to accommodate a 19mm minimum deviation in O.D. size.

5.0 Fasteners

- 5.1 All fasteners shall be injected molded glass reinforced nylon, 316 stainless steel, or pultruded Vinyl Ester rod with ground threads and compression molded Vinyl Ester nuts.

6.0 Acceptable Manufacturer

- 6.1 The fibreglass cable management system component shall be manufactured by Treadwell Group Pty Ltd of Australia.

Instrumentation & Push Button Stands

Instrumentation & Push Button Stands





EXduro™ Instrumentation & Push Button Stands have great resilience and exceptional durability due to their all fibreglass reinforced plastic (FRP) construction. As a result, these stands cost substantially less in the long run than metallic stands with a high grade paint coat or even stainless steel instrument stands.

Furthermore, these products are all lightweight in comparison with galvanised and other metallic stands available on the market. Installation is also made easy by, not only the lightweight properties of the products, but also the fact the system can be easily adjusted and reconfigured if required on site i.e. no hot works for cutting of metal or welding is required, therefore eliminating the need for such permits.

These stands can also be customised to achieve any type of configuration – whether your requirement is for a double or a single post, large mounting panel type design or even various mounting and weight requirements – Treadwell can do it with our EXduro™ Instrumentation & Push Button Stand Systems.

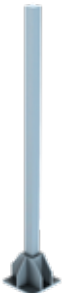











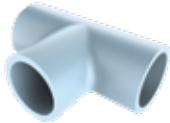
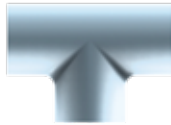

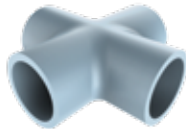
Made from FRP, these products will not rust or rot when exposed to chemicals and environments that would typically cause traditional products to start oxidising very quickly. Last but not least, the product is compatible with metallic and concrete structures without the requirement for insulation and is sturdy enough for any heavy industrial application. Consider the EXduro™ Instrumentation & Push Button Stand system if you are serious about capitalising on real design life cost advantages.



Floor Mount Single	Column or Wall Mount	Floor Mount, Multiple Instrument
EXD-SD-01-(RS)(C)	EXD-SD-02-(RS)(C)	EXD-SD-03-(RS)(C)
		
Floor Mount Double	Floor Mount Triple	Push Button Station
EXD-SD-04-(RS)(C)	EXD-SD-05-(RS)(C)	EXD-SD-06-(RS)(C)
		

Dimensions can be customised to suit.

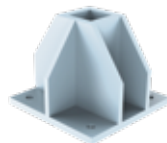
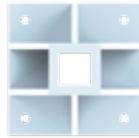
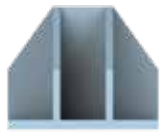
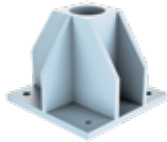
Instrumentation & Push Button Stands

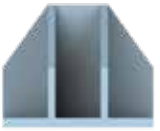
90° Corner Connection Joint	3D	PLAN	ELEVATION
EXD-SD-CCJ-(RS)(C)			
Tee Connection Joint	3D	PLAN	ELEVATION
EXD-SD-TCJ-(RS)(C)			
Cross Connection Joint	3D	PLAN	ELEVATION
EXD-SD-XCJ-(RS)(C)			
Square Tube	3D	PLAN	ELEVATION
EXD-SD-ST-(RS)(C)-(L)			
Round Tube	3D	PLAN	ELEVATION
EXD-SD-RT-(RS)(C)-(L)			
Square Base	3D	PLAN	ELEVATION
EXD-SD-SB-(RS)(C)			
Round Base	3D	PLAN	ELEVATION
EXD-SD-RB-(RS)(C)			

Chemical Resistance Guide

Information contained in this guide is based on data collected from several years of actual industrial applications. Recommendations are based on conservative evaluations of the changes which occur in certain properties of replicate laminates after exposures of one year or longer, both in the laboratory and the field.

Temperatures are neither the minimum nor the maximum but represent standard test conditions (Room Temperature & 70°C). The products may be suitable at higher temperatures but individual test data should be required to establish such suitability. Contact Treadwell for any special applications that you may have.

The recommendations (• : resistant – :not resistant) contained in this specification sheet are made without guarantee or representation as to results. We suggest that you evaluate these recommendations and suggestions in your own laboratory or actual field trial prior to use. Our responsibility for claims arising from breach of warranty, negligence, or otherwise **is limited to the purchase price of the material.**

Chemical	I-Series®		V-Series®	
	Room Temp	70°C	Room Temp	70°C
Acetaldehyde	—	—	—	—
Acetic Acid 0-25%	•	•	•	•
Acetic Acid 25-50%	•	—	•	•
Acetic Anhydride	—	—	—	—
Acetone	—	—	—	—
Acrylonitrile	—	—	—	—
Alcohol, Butyl	—	—	•	—
Alcohol, Ethyl 10%	—	—	•	66
Alcohol, Ethyl 100%	—	—	•	—
Alcohol, Isopropyl 10%	—	—	•	66
Alcohol, Isopropyl 100%	—	—	•	—
Alcohol, Methyl 10%	—	—	•	66
Alcohol, Methyl 100%	—	—	—	—
Alcohol, Methyl Isobutyl	—	—	•	66
Alcohol, Secondary Butyl	—	—	•	66
Aluminium	•	•	•	•
Aluminium Chloride	•	•	•	•
Aluminium Hydroxide	•	—	•	49
Aluminium Nitrate	•	•	•	•
Aluminium Potassium Sulfate	•	•	•	•
Ammonia, Aqueous 0-10%	—	—	•	38
Ammonia, Gas	—	—	•	38
Ammonium Bicarbonate	•	—	•	49
Ammonium Bisulfite	—	—	•	49
Ammonium Carbonate	—	—	•	49
Ammonium Citrate	•	—	•	49
Ammonium Fluoride	—	—	•	49
Ammonium Hydroxide 5%	•	—	•	49
Ammonium Hydroxide 10%	•	—	•	49
Ammonium Hydroxide 20%	—	—	•	49
Ammonium Nitrate	•	•	•	49
Ammonium Persulfate	—	—	•	49
Ammonium Phosphate	—	—	•	49
Ammonium Sulfate	•	•	•	•
Arsenious Sulfate	•	—	•	•
O-Benzoyl Benzoic Acid	—	—	•	•
Barium Carbonate	•	—	•	•

Chemical	I-Series®		V-Series®	
	Room Temp	70°C	Room Temp	70°C
Barium Chloride	•	—	•	•
Barium Hydroxide	—	—	•	49
Barium Sulfate	•	•	•	•
Barium Sulfide	—	—	•	•
Beer	•	—	•	49
Benzene	—	—	—	—
5% Benzene in Kerosene	•	—	•	•
Benzene Sulfonic Acid	•	•	•	•
Benzoic Acid	•	—	•	•
Benzyl Alcohol	—	—	•	—
Benzyl Chloride	—	—	—	—
Brass Plating Solution:				
– 3% Copper Cyanide	—	—	•	•
– 6% Sodium Cyanide	—	—	•	•
– 1% Zinc Cyanide	—	—	•	•
– 3% Sodium Carbonate	—	—	•	•
Butyl Acetate	—	—	—	—
Butyric Acid 0-50%	•	—	•	•
Butylene Glycol	•	•	•	•
Cadmium Chloride	•	—	•	•
Cadmium Cyanide Plating Soln:				
– 3% Cadmium Oxide	—	—	•	49
– 6% Sodium Cyanide	—	—	•	49
– 1% Caustic Soda	—	—	•	49
Calcium Bisulfate	•	•	•	•
Calcium Carbonate	•	—	•	•
Calcium Chlorate	•	•	•	•
Calcium Chloride	•	•	•	•
Calcium Hydroxide	•	—	•	49
Calcium Hypochlorite	•	—	•	49
Calcium Nitrate	•	•	•	•
Calcium Sulfate	•	•	•	•
Calcium Sulfite	•	•	•	•
Caprylic Acid	•	—	•	•
Carbon Dioxide	•	•	•	•
Glycerine	•	•	•	•
Glycol, Ethylene	•	•	•	•

Chemical Resistance Guide

Chemical	I-Series®		V-Series®	
	Room Temp	70°C	Room Temp	70°C
Glycol, Propylene	•	•	•	•
Glycolic Acid	•	—	•	•
Gold Plating Solution:				
– 63% Potassium Ferrocyanide	—	—	•	•
– 2% Potassium Gold Cyanide	—	—	•	•
– 8% Sodium Cyanide	—	—	•	•
Heptane	•	—	•	•
Hexane	•	—	•	•
Hexylene Glycol	•	•	•	•
Hydraulic Fluid	•	—	•	•
Hydrobromic Acid 0-25%	•	—	•	•
Hydrochloric Acid 0-37%	•	—	•	•
Hydrocyanic Acid	•	—	•	•
Hydrofluoric Acid 10%	—	—	•	—
Hydrofluosilicic Acid, 10%	—	—	•	•
Hydrogen Bromide, Wet Gas	—	—	•	•
Hydrogen Chloride, Dry Gas	—	—	•	•
Hydrogen Chloride, Wet Gas	—	—	•	•
Hydrogen Peroxide	—	—	•	49
Hydrogen Sulfide, Dry	•	—	•	•
Hydrogen Sulfide, Aqueous	•	—	—	•
Hydrogen Fluoride, Vapour	—	—	•	•
Hydrosulfite Bleach	—	—	•	49
Hydrochlorus Acid 0-10%	—	—	—	—
Iron Plating Solution:				
– 45% Fecl: 15% Cacl	—	—	•	•
– 20% Fecl: 11% (Nh4)2 So4	—	—	•	•
Iron And Steel Cleansing Bath:				
–9% Hydrochloric: 23% Sulfuric	—	—	•	•
Isopropyl Amine	—	—	•	38
Isopropyl Palmitate	•	•	•	•
Jet Fuel	•	—	•	•
Kerosene	•	—	•	•
Lactic Acid	•	—	•	•
Lauroryl Chloride	—	—	•	•
Lauric Acid	•	—	•	•
Lead Acetate	•	—	•	•
Lead Chloride	•	—	•	•
Lead Nitrate	•	—	•	•
Lead Plating Solution:				
–.8% Fluoboric, 0.4% Boric Acid	—	—	•	•
Levulinic Acid	•	—	•	•
Linseed Oil	•	•	•	•
Lithium Bromide	•	•	•	•
Lithium Sulfate	•	•	•	•

Chemical	I-Series®		V-Series®	
	Room Temp	70°C	Room Temp	70°C
Magnesium Bisulfite	•	—	•	•
Magnesium Carbonate	•	—	•	•
Magnesium Chloride	•	•	•	•
Magnesium Hydroxide	—	—	•	60
Magnesium Nitrate	•	—	•	•
Magnesium Sulfate	•	•	•	•
Maleic Acid	•	•	•	•
Mercuric Chloride	•	—	•	•
Mercurous Chloride	•	—	•	•
Methylene Chloride	—	—	—	—
Methyl Ethyl Ketone	—	—	—	—
Methyl Isobutyl Carbitol	—	—	—	—
Methanol (See Alcohol)	•	—	•	•
Methyl Isobutyl Ketone	—	—	—	—
Methyl Styrene	—	—	—	—
Mineral Oils	•	•	•	•
Molybdenum Disulfide	•	—	•	•
Monochloro Acetic Acid	—	—	—	—
Monoethanolamine	—	—	—	—
Motor Oil	•	•	•	•
Myristic Acid	—	—	•	•
Naptha	•	•	•	•
Napthalene	•	—	•	•
Nickel Chloride	•	•	•	•
Nickel Nitrate	•	•	•	•
Nickel Plating:				
– 8% Lead, 0.8% Flouboric Acid	—	—	•	•
– 0.4% Boric Acid	—	—	•	•
Nickel Plating:				
– 11% Nickel Sulfate	•	—	•	•
– 2% Nickel Chloride	•	—	•	•
– 1% Boric Acid	•	—	•	•
Nickel Plating:				
– 44% Nickel Sulfate	•	—	•	•
– 4% Ammonium Chloride	•	—	•	•
– 4% Boric Acid	•	—	•	•
Nickel Sulfate	•	•	•	•
Nitric Acid 0-5%	•	•	•	•
Nitric Acid 20%	—	—	•	49
Nitric Acid Fumes	—	—	—	—
Nibrobenzene	—	—	—	—
Octanoci Acid	•	—	•	•
Oil, Sour Crude	•	•	•	•
Oil, Sweet Crude	•	•	•	•
Oleic Acid	•	•	•	•

Chemical Resistance Guide

Chemical	I-Series®		V-Series®	
	Room Temp	70°C	Room Temp	70°C
Oleum (Fuming Sulfuric)	—	—	—	—
Olive Oil	•	•	•	•
Oxalic Acid	•	•	•	•
Peroxide Bleach:				
– 25% Peroxide 95%	•	•	•	•
– 0.025% Epsom Salts	•	•	•	•
– 5% Sodium Silicate 42.Be	•	•	•	•
– 1.4% Sulfuric Acid 66.Be	•	•	•	•
Phenol	—	—	—	—
Phenol Sulfonic Acid	—	—	—	—
Phosphoric Acid	•	•	•	•
Phosphoric Acid Fumes	•	•	•	•
Phosphorous Pentoxide	•	•	•	•
Phosphorous Trichloride	—	—	—	—
Phthalic Acid	•	•	•	•
Pickling Acids(Sulfuric & Hydrochloric)	•	•	•	•
Picric Acid, Alcoholic	—	—	—	—
Polyvinyl Acetate Latex	•	—	•	•
Polyvinyl Alcohol	•	—	•	38
Polyvinyl Chloride Latex W/35(Parts Dop)	—	—	•	49
Potassium Aluminium Sulfate	•	•	•	•
Potassium Bicarbonate	•	—	•	60
Potassium Bromide	•	—	•	38
Potassium Carbonate	•	—	•	60
Potassium Chloride	•	•	•	•
Potassium Dichromate	•	—	•	60
Potassium Ferricyanide	•	•	•	•
Potassium Ferrocyanide	•	•	•	•
Potassium Hydroxide	—	—	•	66
Potassium Nitrate	•	•	•	•
Potassium Permanganate	•	—	•	60
Potassium Persulfate	•	—	•	•
Potassium Sulfate	•	•	•	•
Propionic Acid 1-50%	—	—	•	49
Propionic Acid 50-100%	—	—	—	—
Propylene Glycol	•	•	•	•
Pulp Paper Mill Effluent	•	—	•	•
Pyridine	—	—	—	—
Salicylic Acid	—	—	•	60
Sebacic Acid	—	—	•	•
Selenious Acid	—	—	•	•
Silver Nitrate	•	•	•	•
Silver Plating Solution:				
– 44% Silver Cyanide	—	—	•	•
– 7% Potassium Cyanide	—	—	•	•

Chemical	I-Series®		V-Series®	
	Room Temp	70°C	Room Temp	70°C
– 5% Sodium Cyanide	—	—	•	•
– 2% Potassium Carbonate	—	—	•	•
Soaps	•	—	•	•
Sodium Acetate	•	—	•	•
Sodium Benzoate	•	—	•	•
Sodium Bicarbonate	•	•	•	•
Sodium Bifluoride	•	—	•	49
Sodium Bisulfate	•	•	•	•
Sodium Bisulfite	•	•	•	•
Sodium Bromate	•	•	•	60
Sodium Bromide	•	•	•	•
Sodium Carbonate 0-25%	•	—	•	•
Sodium Chlorate	•	—	•	•
Sodium Chloride	•	•	•	•
Sodium Chlorite	•	—	•	•
Sodium Chromite	•	•	•	•
Sodium Cyanide	•	—	•	•
Sodium Dichromate	•	•	•	•
Sodium Di-Phosphate	•	•	•	•
Sodium Ferricyanide	•	•	•	•
Sodium Fluoride	•	—	•	49
Sodium Fluoro Silicate	—	—	•	49
Sodium Hexametaphosphates	—	—	•	38
Sodium Hydroxide 0-5%	—	—	•	66
Sodium Hydroxide 5-25%	—	—	•	66
Sodium Hydroxide 50%	—	—	•	66
Sodium Hydrosulfide	•	—	•	•
Sodium Hypochlorite	•	—	•	66
Sodium Lauryl Sulfate	•	•	•	•
Sodium Mono-Phosphate	•	•	•	•
Sodium Nitrate	•	•	•	•
Sodium Silicate	•	—	•	•
Sodium Sulfate	•	•	•	•
Sodium Sulfide	•	—	•	•
Sodium Sulfite	•	—	•	•
Sodium Tetra Borate	•	•	•	•
Sodium Thiocyanate	—	—	•	•
Sodium Thiosulfate	•	—	•	•
Sodium Tripolyphosphate	•	—	•	•
Sodium Xylene Sulfonate	•	—	•	•
Sodium Solutions	•	—	•	•
Sodium Crude Oil	•	•	•	•
Soya Oil	•	•	•	•
Stannic Chloride	•	•	•	•
Stannous Chloride	•	•	•	•

Chemical Resistance Guide

Chemical	I-Series®		V-Series®	
	Room Temp	70°C	Room Temp	70°C
Stearic Acid	•	•	•	•
Styrene	—	—	—	—
Sugar, Beet And Cane Liquor	•	—	•	•
Sugar, Sucrose	•	•	•	•
Sulfamic Acid	•	—	•	•
Sulfanilic Acid	•	—	•	•
Sulfated Detergents	•	—	•	•
Sulfur Dioxide, Dry Or Wet	—	—	•	•
Sulfur Trioxide/Air	—	—	•	•
Sulfuric Acid 0-30%	•	•	•	•
Sulfuric Acid 30-50%	—	—	•	•
Sulfuric Acid 50-70%	—	—	•	49
Sulfurous Acid	—	—	•	38
Superphosphoric Acid (76% P2 O5)	•	—	•	•
Tall Oil	•	—	•	60
Tannic Acid	•	—	•	66
Tartaric Acid	•	•	•	•
Thionyl Chloride	—	—	—	—
Tin Plating:				
– 18% Stannous Fluorborate	—	—	•	•
– 7% Tin	—	—	•	•
– 9% Fluoroboric Acid	—	—	•	•
– 2% Boric Acid	—	—	•	•
Toluene	—	—	—	—
Toluene Sulfonic Acid	—	—	•	•
Transformer Oils:				
– Mineral Oil Types	•	•	•	•
– Chloro-Phenyl Types)	•	•	•	•
Trichlor Acetic Acid	•	—	•	•
Trichlorethylene	—	—	—	—
Trichloropenol	—	—	—	—
Tricresyl Phosphate	—	—	•	49
Tridecylbenzene Sulfonate	•	—	•	•
Trisodium Phosphate	•	—	•	•
Turpentine	—	—	•	38
Urea	—	—	•	38
Vegetable Oils	•	•	•	•
Vinagar	•	•	•	•
Vinyl Acetate	—	—	—	—
Water:				
– Deionised	—	—	—	—
– Demineralised	•	•	•	•
– Distilled	•	•	•	•
– Fresh	•	•	•	•
– Salt	•	•	•	•

Chemical	I-Series®		V-Series®	
	Room Temp	70°C	Room Temp	70°C
– Sea	•	•	•	•
White Liquor (Pulp Mill)	•	—	•	•
Xylene	—	—	—	—
Zinc Chlorate	•	•	•	•
Zinc Nitrate	•	•	•	•
Zinc Plating Solution:				
– 9% Zinc Cyanide	—	—	•	49
– 4% Sodium Cyanide	—	—	•	49
–9% Sodium Hydroxide	—	—	•	49
Zinc Plating Solution:				
– (49% Zinc Fluoroborate	•	—	•	•
– 5% Ammonium Chloride	•	—	•	•
– 6% Ammonium Fluoroborate	•	—	•	•
Zinc Sulfate	•	•	•	•

Notes

A large grid of graph paper for taking notes, consisting of 20 columns and 30 rows of small squares.

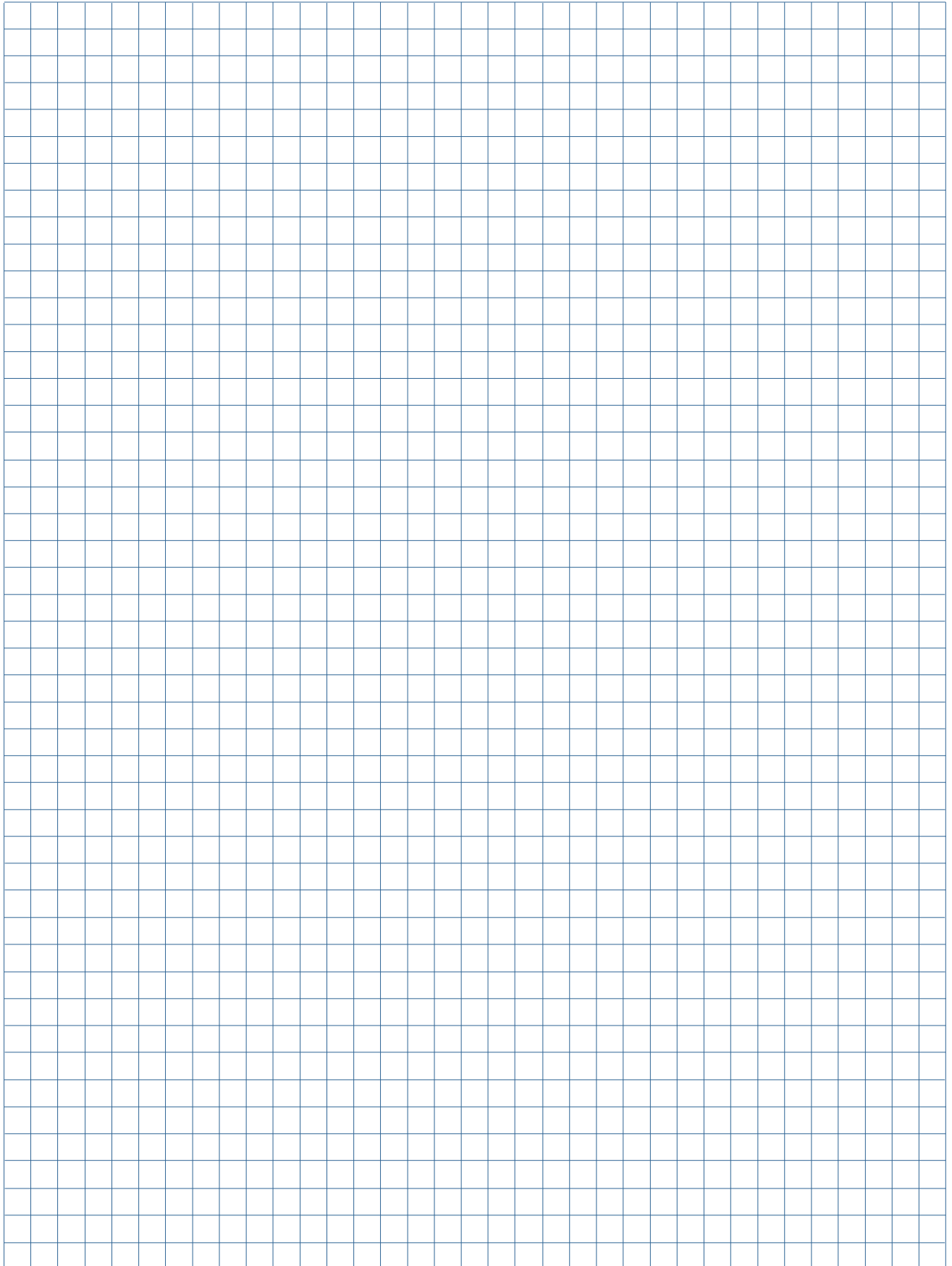

Notes

A large grid of graph paper for taking notes, consisting of 20 columns and 30 rows of small squares.





TREADWELL™

Treadwell brands mentioned in this document are all registered brands of Treadwell Group Pty Ltd. All pictures and information are supplied as a guide only. The complete range of Treadwell products are developed, refined, made to meet and exceed stringent specifications for the worldwide market.

Important Note: Sales of products are subject to our Terms and Conditions which are available upon request. All specifications and photos are a guide only and are subject to change without notice. Please ring to confirm details. Treadwell products stated only comply with relevant standards mentioned within this publication when installed and used as they are designed to be.

